

LUDOCUADERNO

PARA NIÑOS Y NIÑAS

3-6
años



Gobierno
de Chile

gob.cl

Chile
crece
contigo

Protección Integral a la Infancia

DIBUJOS

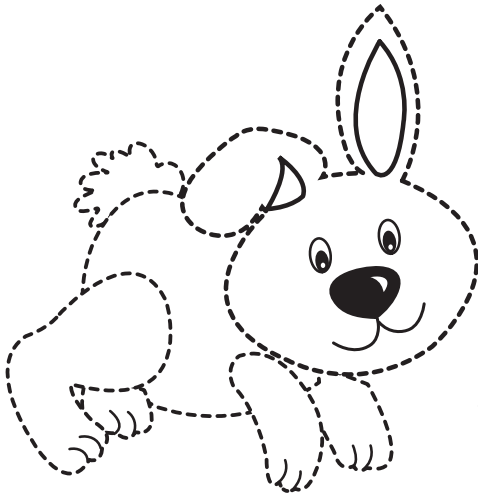
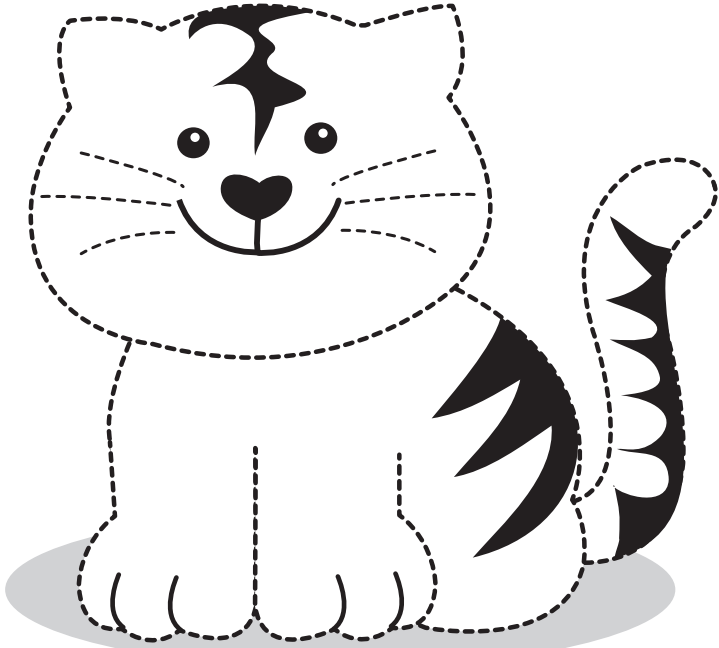

...Bien
Hecho!!



Al dibujar se desarrolla
también la capacidad
para organizar el
pensamiento.



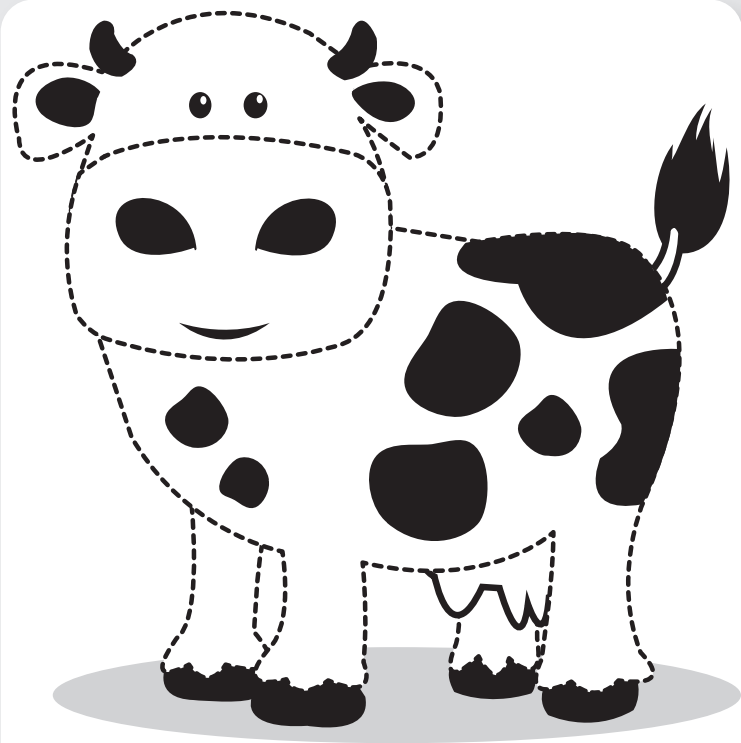

JUNTA LAS ACCIONES

Une con una línea los opuestos que corresponden.

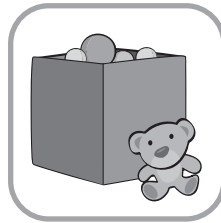

UNE LAS SOMBRAS

Une con una línea las sombras que corresponde a cada animalito.

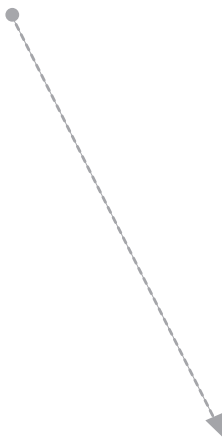
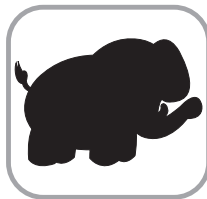
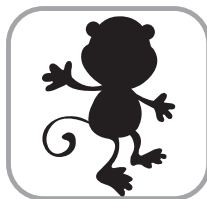

PINTA LOS MANDALAS

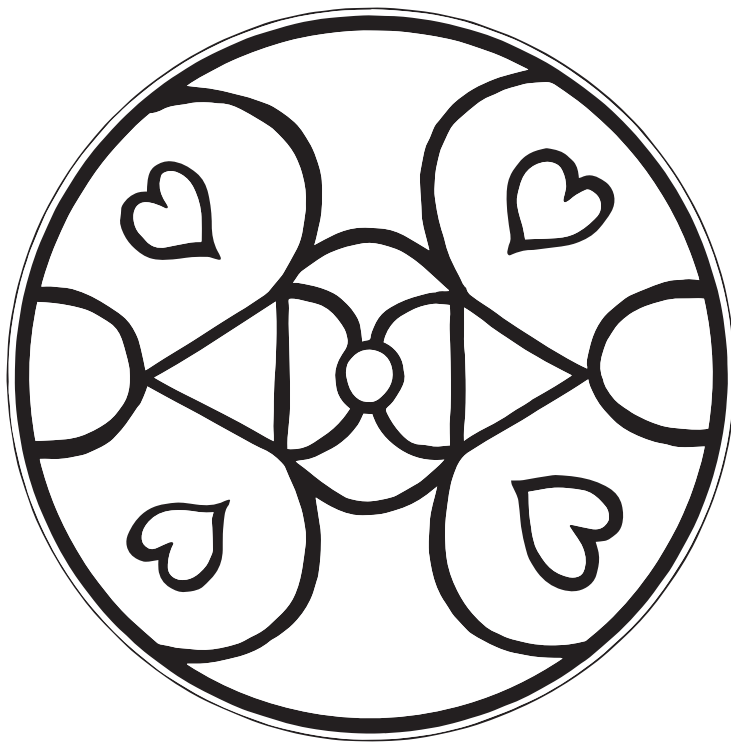

*Pinta con diferentes colores
y diviértete!*

MANDALAS

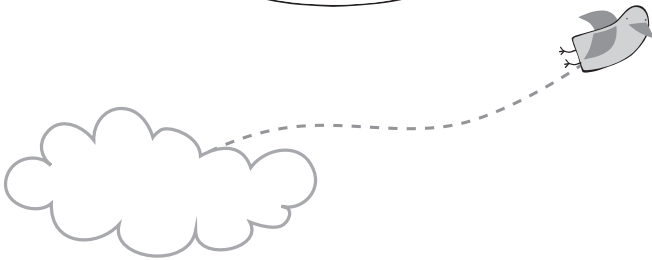
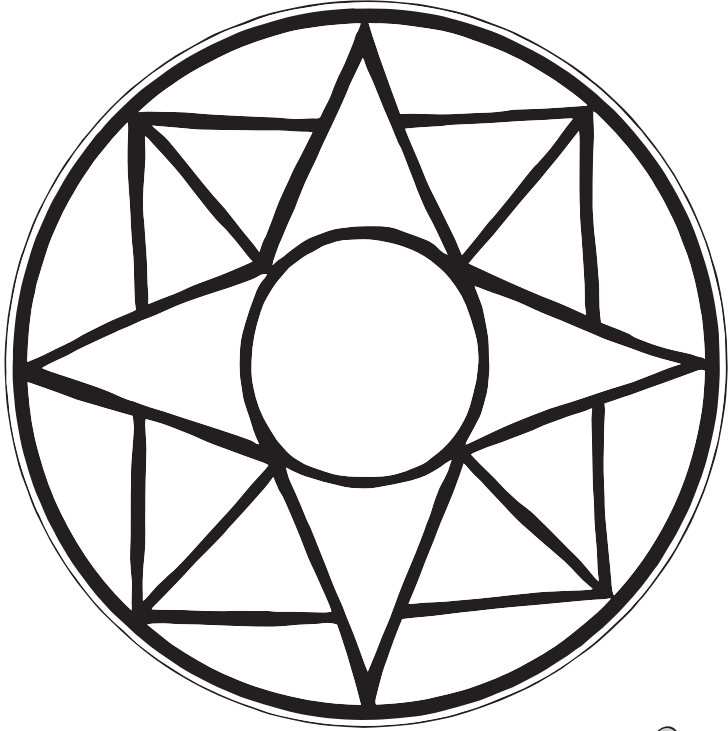

MANDALAS

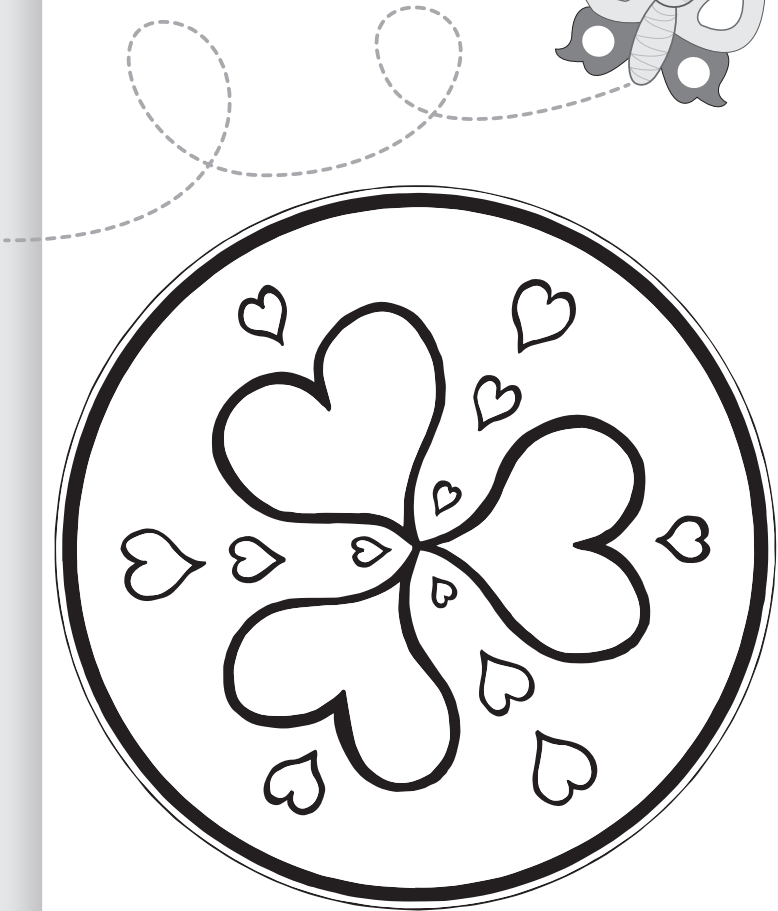
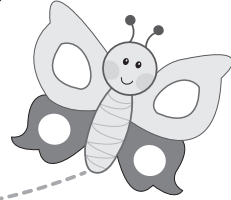

MANDALAS

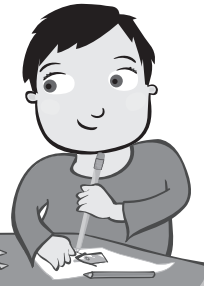
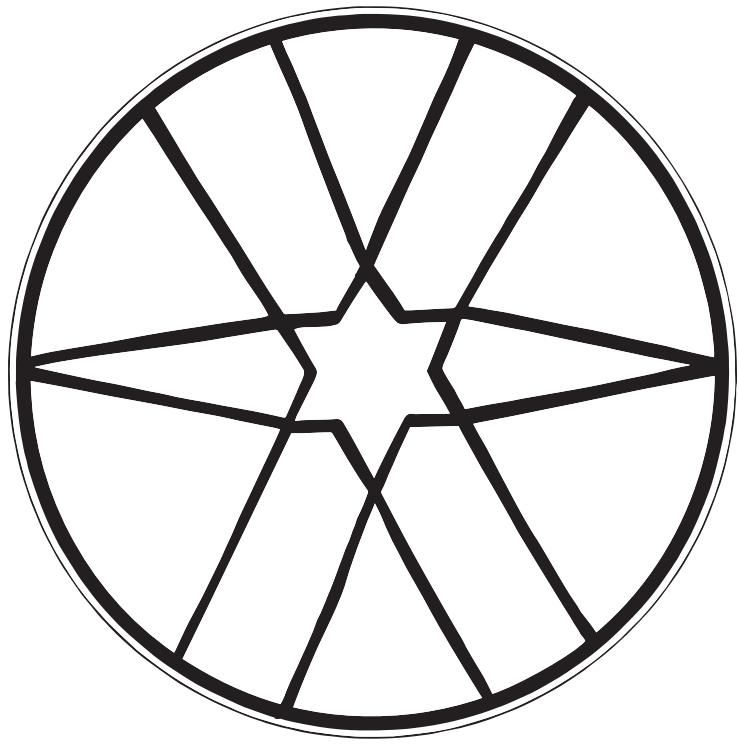

MANDALAS

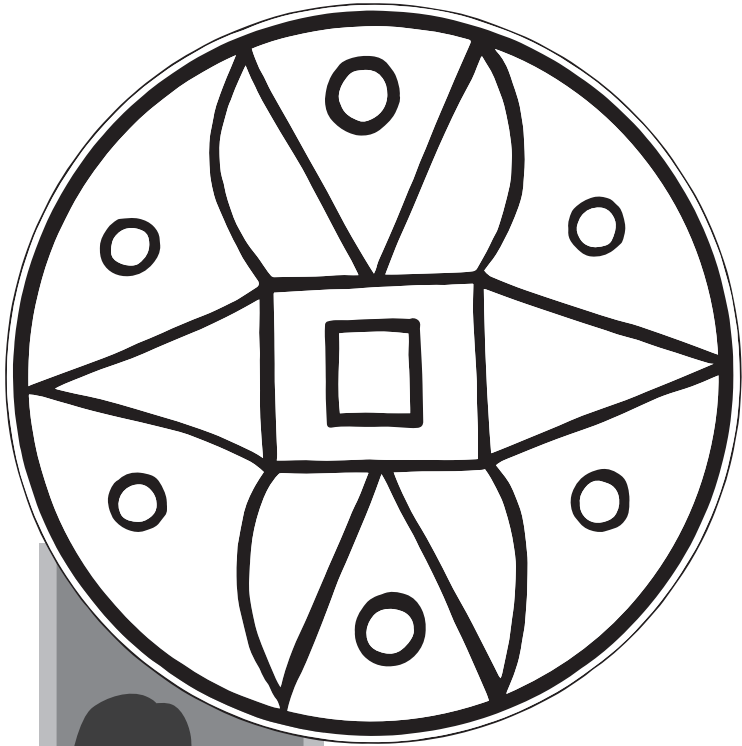

MANDALAS

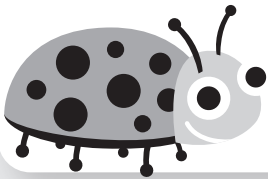
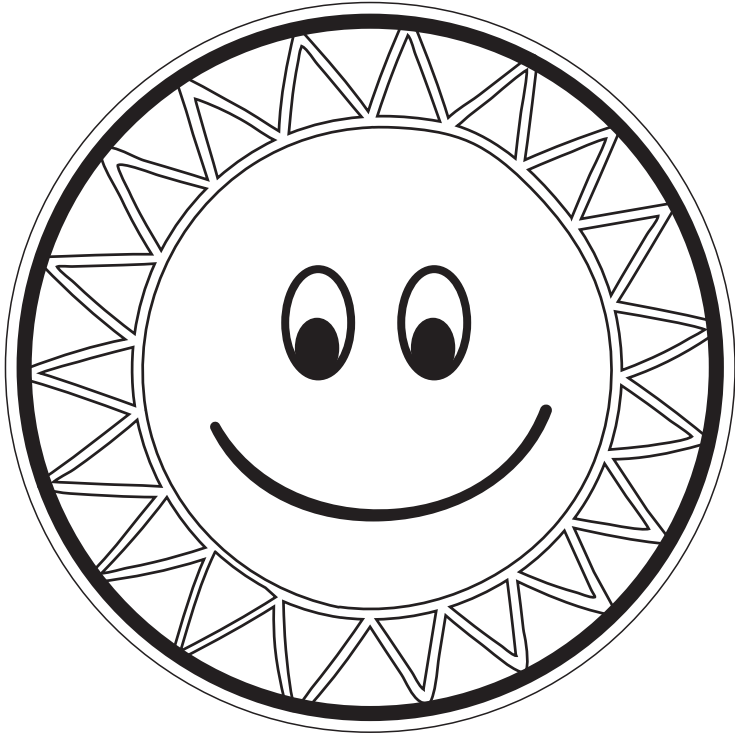

MANDALAS

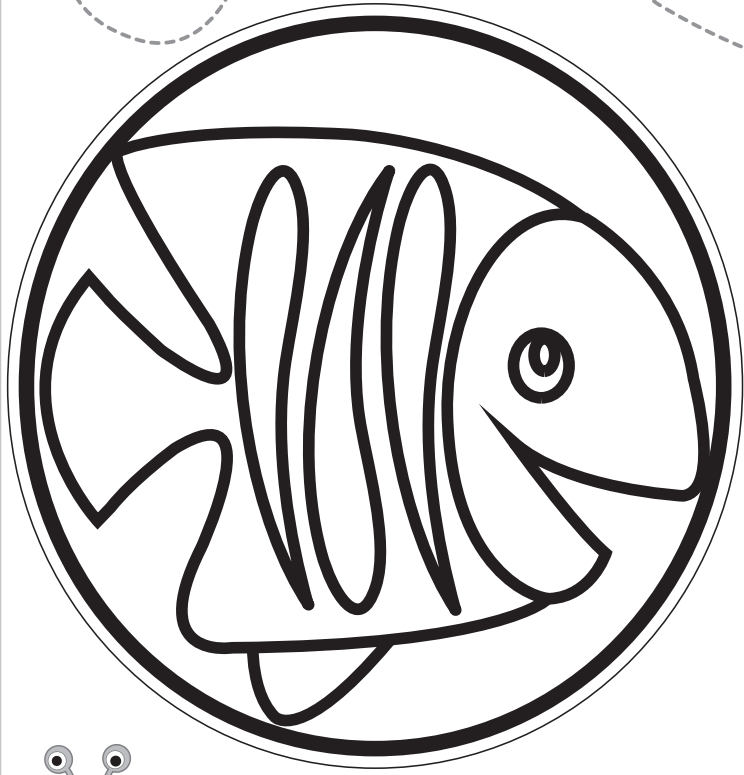

MANDALAS

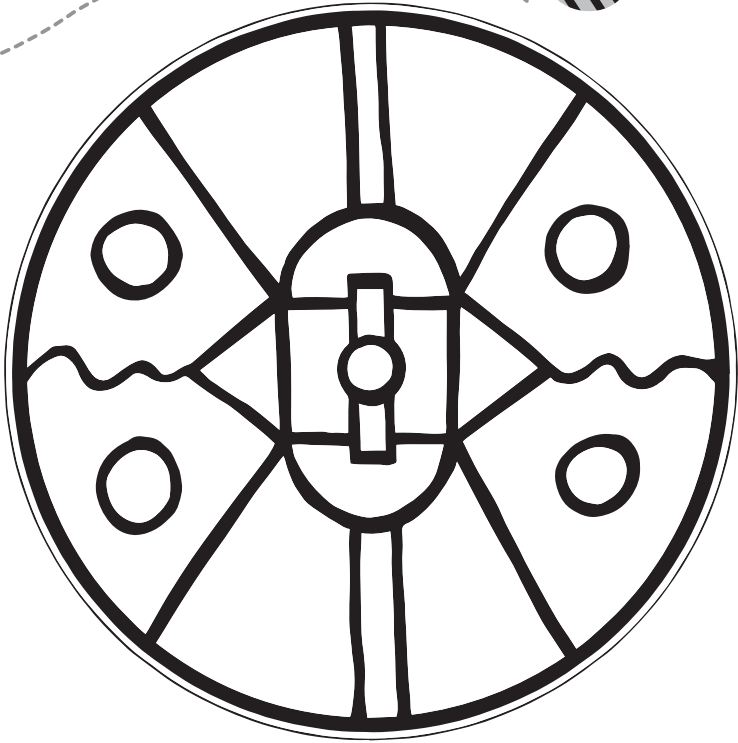

...Bien Hecho!!

PARTES DE TU CARA



Incentiva a tu niño(a) para que reconozca las partes de su cara.

PARTES DE TU CUERPO



Motívale para que reconozca partes de su cuerpo
y te diga para qué sirven.

DIBUJA TU FAMILIA

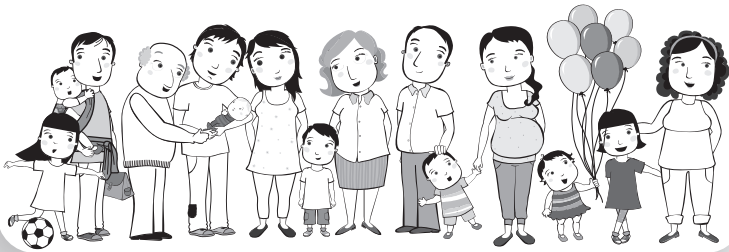
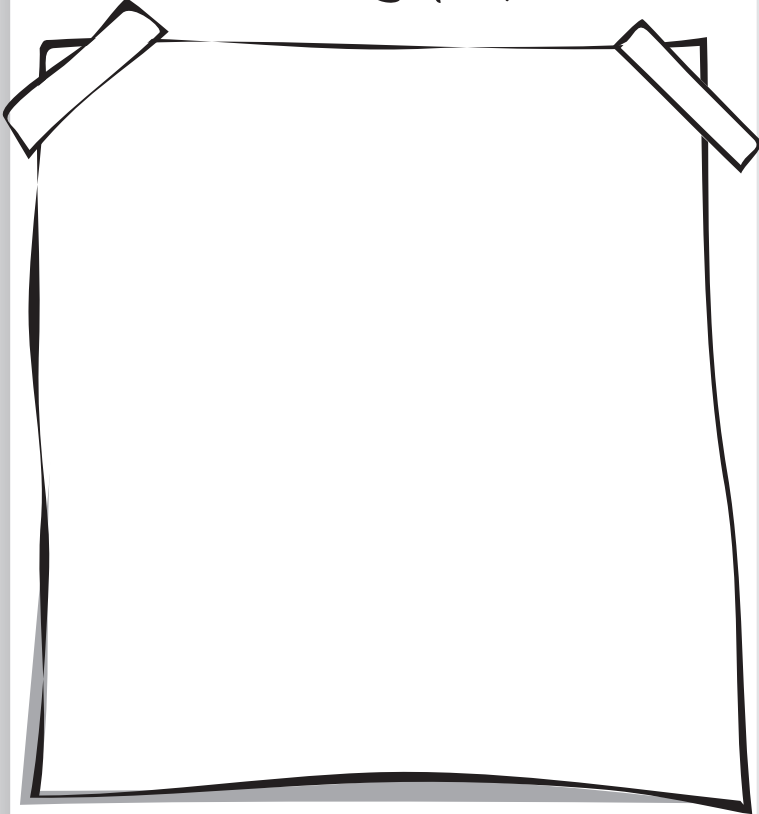

DIBUJA A TUS AMIGOS

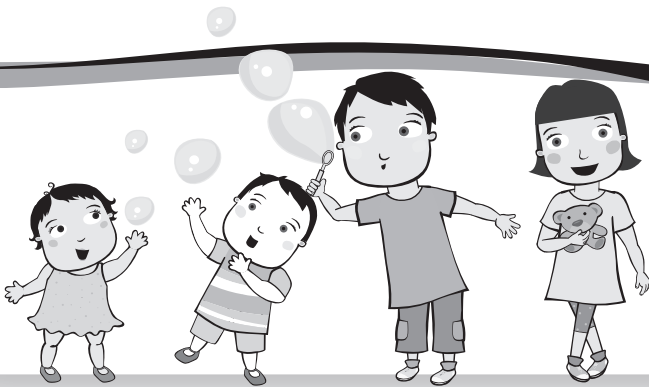
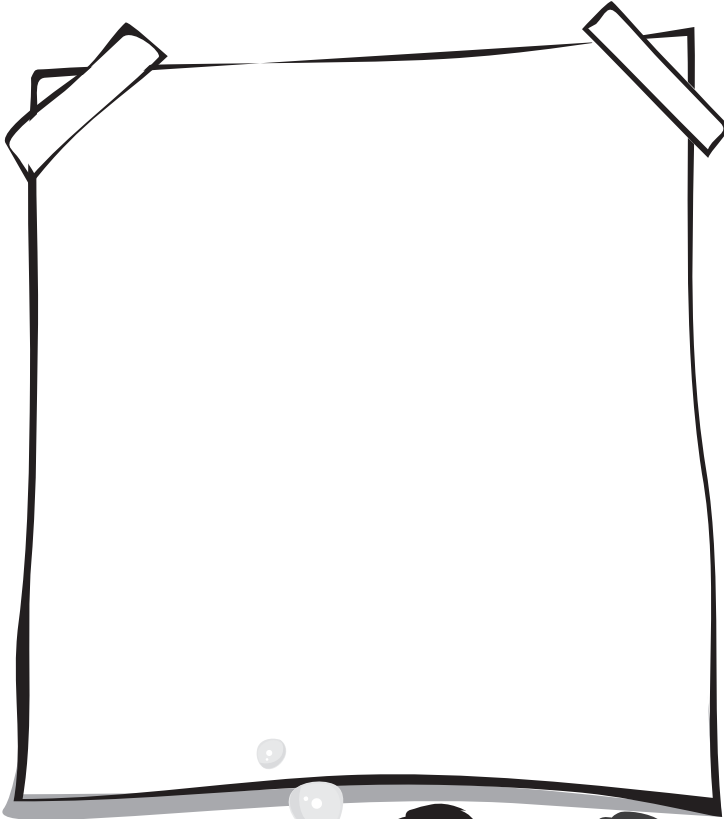

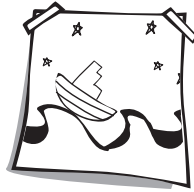
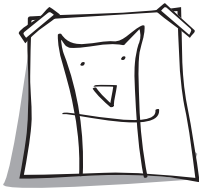

**Dibuja el animal que
más te guste.**

DIBUJA LO QUE QUIERAS

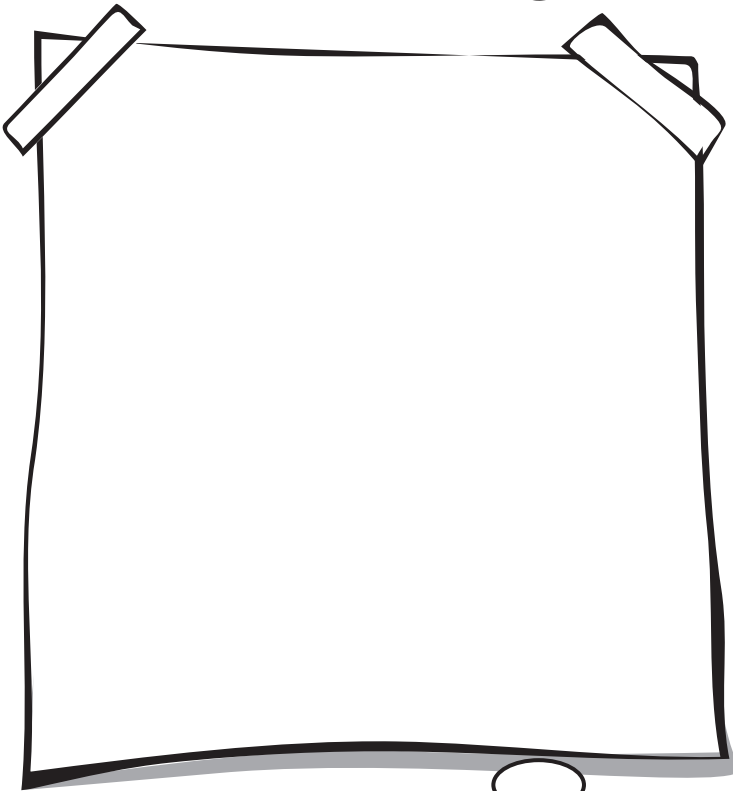

A BUSCAR...

Junta las figuras grandes con las chicas.

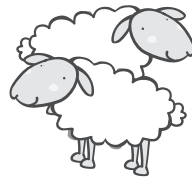
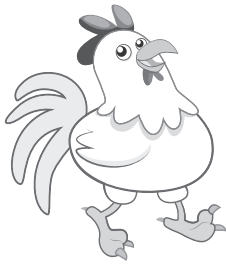
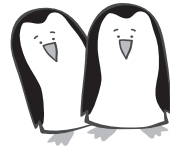
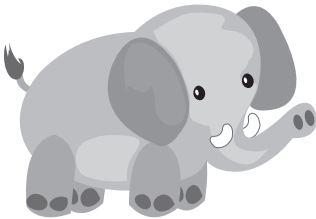
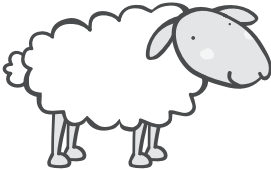
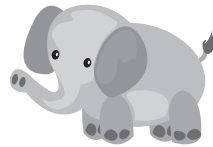

¡Disfruta el juego!

BUSCA LA SOMBRA

Une con una línea los animalitos con las
sombras de sus pisadas.

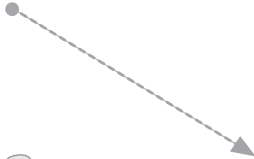
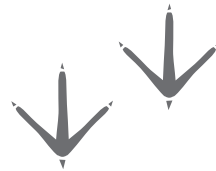
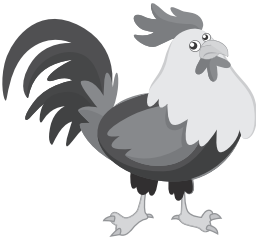
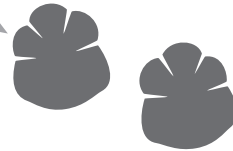
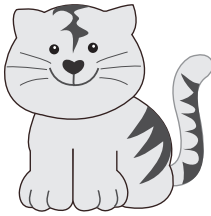
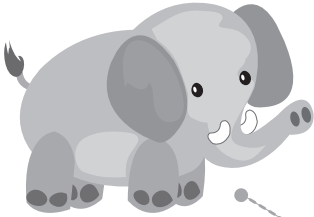

SIGUE EL CAMINO ...

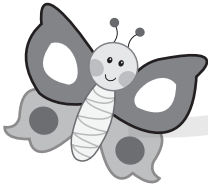
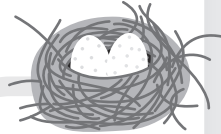

¡Muy bien!

PINTA Y CUENTA

Coloca en cada vagón el número de animalitos que lleva cada uno.

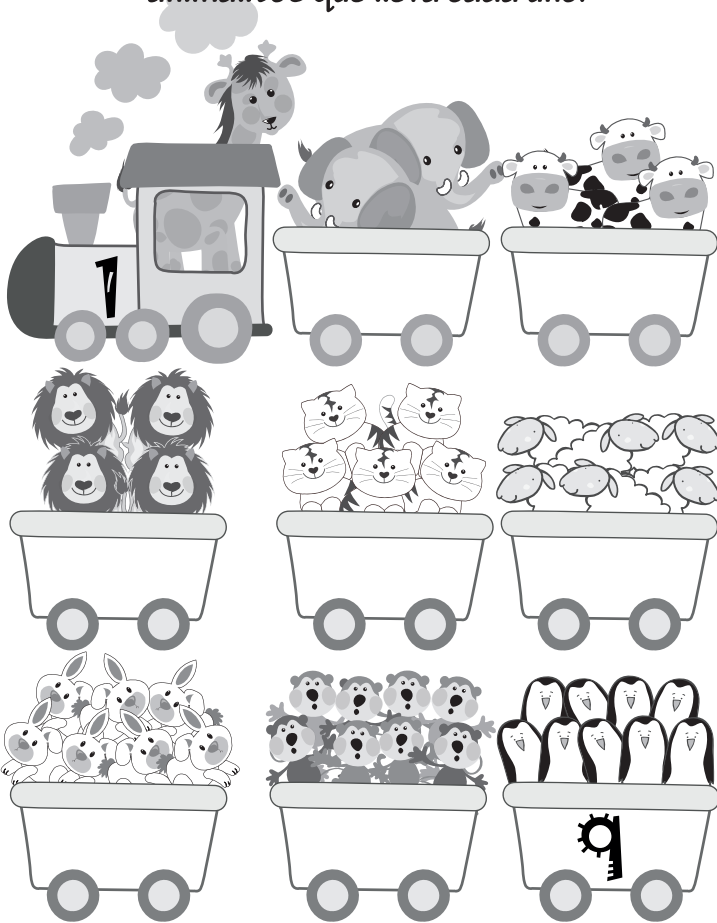



2 3 4 5 6 7 8

CUENTA UN CUENTO

Reunión de Animales

Estaban un día el  guau-guau sentado
al lado del  miau-miau.

Este al lado del  cua-cuá y este al lado del
 kikiriki y al lado de la  cocrócó.

Y esta al lado de la  beeeeeee y
todos juntos buscaban a la  muuuuu.
Pero la  muuuuu se había extraviado pastando,
y pastando se había alejado.

Entonces los animales pensaron: "si la llamamos
todos juntos, ella escuchará y volverá".

Y así fue: el  maulló, el  ladró,
el  graznó, el  cantó,
la  cacareó y la  baló.

Lo hicieron tan fuerte, que la  escuchó
y también mugió, hasta que llegó donde sus amigos,
a los cuales abrazó.

MEMORAMA

Pinta memorizando los
los animalitos.

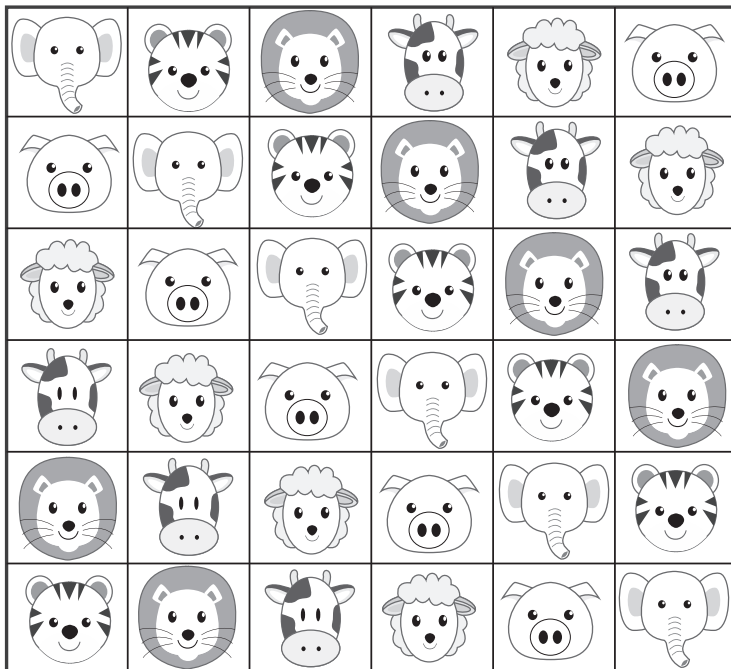

Pinta los elefantes de color gris, los tigres de amarillo,
los leones de café, las vacas de rosado, las ovejas de celeste
y los chanchos de rojo.

¡Bien hecho!

Encuentra más materiales e información sobre estimulación, crianza respetuosa y desarrollo infantil en:



www.crececontigo.cl



Facebook/chcrececontigo



Twitter@CreceContigo



Youtube/Chile Crece Contigo

Chile Crece Contigo es parte del Sistema de Promoción y Protección Social que coordina el Ministerio de Desarrollo Social y Familia. Una iniciativa del Estado de Chile que promueve la equidad desde el comienzo de la vida.